



SLABBINCK®

2024 - 2025

The next Jubilee will be in 2025 and there is great expectation among the faithful all over the world.

It is the second Jubilee with Pope Francis, after the extraordinary one 10 years ago. Pilgrims of hope is the motto the Pontiff adopted for the 2025 Jubilee, with the desire to revive the spirit and sense of community around the world, after difficult years of suffering, hardship and isolation.

The Jubilee is a year of special grace, in which the Catholic Church offers the possibility to ask for a plenary indulgence, i.e. the forgiveness of sins for oneself or one's deceased family members. Plus, it is an opportunity to reconnect with one's faith and with others in a spiritual celebration of reconciliation.

The Jubilee runs from just before Christian Christmas to the Epiphany, that is, from December 2024 to January 2026.





5036

766-7672

864-7672

862-7672



7672

50-7672



5396

Jubilee 2025 set

Chasuble in **Pius**, 100% man-made fibres, width 63", length 53", with printed **Deco**-fabric band.

7672 Chasuble	\$ 525.00
50-7672 Overlay stole in Deco -fabric printed; style 25	\$ 325.00
862-7672 Lectern cover, Deco -fabric printed	\$ 112.00
864-7672 Altar cover in Deco -fabric printed.	\$ 185.00

Banner in **Deco**-fabric, 100% man-made fibres. Height 9', width 3 3/4'. Finished at top with open hem; with wooden rod, 2 wooden apples and hanging cord. Metal dowel at bottom, incorporated into hem.

766-7672 Banner	\$ 188.00
------------------------	------------------

Chasuble in **Dupion**, 70% man-made fibres and 30% viscose, width 59", length 53". With orphreys and machine embroidered Jubilee emblem.

5396 Chasuble, roll-collar "3"	\$ 1,240.00
Machine embroidered Jubilee design on the fabric.	
5403 Chasuble, roll-collar "3"	\$ 745.00
Band in velvet, finished with gold-gallon and machine embroidered Jubilee emblem.	
5410 Chasuble, roll-collar "4"	\$ 1,840.00

Other languages available, see our website www.slabbinct.com



5403

5410



2-5391

2-5391

2-5391

2-5391

Monastic chasuble, in **Sentia**, fabric of 55% silk and 45% man-made fibres; width 59", length 53"; with inside stole. With machine embroidered crosses.

2-5391 Monastic chasuble, roll-collar "4"

\$ 1,835.00

Also available in **Dupion**

\$ 1,240.00

*Standard order 5391 will always be delivered in **Sentia**.*

Chasuble in **Dupion**, 70% man-made fibres and 30% viscose, width 59", length 53"; with inside stole.

With machine embroidered design on **Dupion** band.

5382	Chasuble	\$ 1,070.00
5383	Chasuble	\$ 990.00
5384	Chasuble	\$ 1,225.00
5385	Chasuble	\$ 990.00

Overlay stole in **Dupion**, style 25

50-5382	Overlay	\$ 355.00
50-5383	Overlay	\$ 360.00
50-5384	Overlay	\$ 400.00
50-5385	Overlay	\$ 370.00



5382

5385

5383

5384



50-5382 50-5383 50-5384 50-5385



5289

5379

5380

5381

Chasuble, in **Duomo**, 100% man-made fibres, width 63", length 53"; with inside stole; digitally printed design on damask banding.

5289 Chasuble \$ 1,565.00

Chasuble in **Pius**, fabric of 100% man-made fibres, width 63", length 53"; with inside stole; with printed image and gold braid.

5379 Our Lady of Perpetual Help \$ 735.00

5380 Our Lady of Guadalupe \$ 735.00

5381 St-Joseph \$ 735.00

5379, 5380 and 5381 are also available in **Dupion**; width 59", length 53"; with inside stole

\$ 815.00

Chasuble in **Duomo**, 100% man-made fibres, width 63", length 53". With woven band and inside stole.

5378 Chasuble \$ 980.00

Also available in **Dupion**, width 59", length 53" \$ 615.00

Pius, width 63", length 53" \$ 535.00

Terlenka, width 59", length 53" \$ 600.00

Standard order **5378** will always be delivered in **Duomo**.

Standard order will always be delivered in **Pius**.



5378

5378

5378

5378

5378 in Pius



3219

3219

3219

3219

Chasuble in **Brugia**, 100% wool, width 59", length 53"; with inside stole. Combination of brocade application and orphreys

3219 Chasuble

\$ 1,600.00



3358

3358

3358

3358

Chasuble in **Brugia**, 100% wool, width 59", length 53"; with inside stole. With banding and decoration around neck in **Goya**, damask fabric, with gold braid and hand embroidered cross.

3358 Chasuble

\$ 1,540.00



5392

5392

5392

5392

5392

In **Duomo**, 100% man-made fibres.

Chasuble, width 63", length 53"; with inside stole, with woven orphrey and emblem.

5392 Chasuble **\$ 1,660.00**

5392 Chasuble, roll-collar "4" **\$ 1,810.00**

In **Pius**, 100% man-made fibres, with orphreys.

Chasuble, width 63", length 53", with inside stole.

5185 Chasuble, roll-collar "3" **\$ 745.00**

Matching:

50-5185 Overlay stole, style 25 **\$ 285.00**

7-5185 Dalmatic, type II **\$ 755.00**

34-5185 Deacon stole **\$ 285.00**

70-5185 Cope **\$ 1,240.00**

72-5185 Mitre, indicate head size **\$ 695.00**



50-5185

5185

7-5185

70-5185

72-5185

34-5185



5374

5374

5374

5374

In **Duomo**, 100% man-made fibres.

Chasuble, width 63", height 53", with inside stole. Beautiful brocade, finished with a small gold braid.

5374 Chasuble, roll-collar "4"

\$ 1,415.00

Beautiful woven galoon.

5290 Chasuble

\$ 1,095.00

Matching:

50-5290 Overlay stole, style 25

\$ 360.00

7-5290 Dalmatic, type IV

\$ 1,360.00

70-5291 Cope

\$ 1,735.00

72-5291 Mitre

\$ 875.00



72-5291



70-5291



7-5290



50-5290



5290



5290



5290



5290



5291



2-5375

2-5375

2-5375

2-5375

2-5375

2-5375

Monastic chasuble in **Linus**, 100% man-made fibres, without embroidery. Width 63", length 53"; with inside stole.

2-5375 Monastic chasuble \$ 985.00

2-5375 Monastic chasuble with roll-collar "3" (not illustrated) \$ 1,105.00

3111

3-3110



7-3111



3111

3111

3111

Chasuble in **Brugia**, 100% wool, with orphreys in **Ornata**.

Width 59", length 53"; with inside stole.

3111 Chasuble, roll-collar "4" \$ 1,205.00

7-3111 Dalmatic, roll-collar "4" \$ 1,205.00

Matching, not illustrated.

70-3111 Cope; standard length 57", or custom-made \$ 1,755.00

72-3111 Mitre; when ordering, please indicate head size \$ 920.00

Chasuble in **Brugia**, 100% wool, without embroidery; width 59", length 53"; without inside stole. In beige, red, dark green or purple. Overlay stole in **Ornata**, style **38**: with tapered flat capuche.

3-3110 Chasuble with overlay stole \$ 895.00

1-92 Chasuble only \$ 545.00

50-3110 Overlay stole only \$ 350.00

SLABBINCK DESIGNER COLLECTION

by Jeroen Kerre

A modern view on symbolism, keeping the tradition of four generations of Slabbinck design.

Manufactured in **Cantate**, of 61% wool, 33% man-made fibres and 6% lurex. Width 63", length 53"; with inside stole.

Machine embroidered with gold and silver coloured threads on woven banding.

3851 Chasuble \$ 1,715.00

50-3851 Overlay stole, style 38: with tapered flat capuche \$ 600.00

Machine embroidered with gold and silver coloured threads on woven banding, with embroidery on the sides and embroidered collar.

2-3850 Monastic chasuble, with embroidered roll-collar "3" \$ 2,550.00

70-3850 Cope; standard length 57", or indicate length \$ 2,830.00

72-3850 Mitre; when ordering, please indicate head size \$ 1,225.00

Monastic chasuble **2-3850** was worn by Pope Benedict XVI, during his visit to Brasil in May 2007. We have the honour to have co-designed this vestment.



50-3851

3851

Seta, the handwoven fabric on which the band is embroidered, may show random knots. These are not to be considered as flaws, but enhance the rustic beauty of this fabric.

2-3850



72-3850

70-3850



5285



50-5285

Liturgical vestments designed for the occasion of the centenary of the apparitions of Our Lady of Fatima. The circular lines symbolize the believers who are gathered around the figure of Our Lady in the square of the pilgrimage site, although each separate, yet connected in prayer. The white fabric refers to the immense light shining during the apparitions. The gold and silver threads in the embroidery, refer to the decorations on the robes of the Virgin.

In **Sentia**, fabric of 55% silk and 45% man-made fibres.

With machine embroidered lines in gold-, silver- and old-gold threads.

5285	Chasuble, roll collar "4", lined; width 59", length 53"; with inside stole	\$ 2,680.00
5286	Chasuble, roll collar "4", lined; width 59", length 53"; with inside stole	\$ 2,190.00
7-5285	Dalmatic, lined	\$ 1,680.00
50-5285	Overlay stole, style 25	\$ 485.00
34-5285	Deacon stole	\$ 485.00
72-5285	Mitre, when ordering, please indicate head size	\$ 995.00



72-5285



5286



7-5285



34-5285

Chasuble in **Dupion**, a knotted yarn dyed fabric, 70% man-made fibres and 30% viscose. With a beautiful hand embroidered emblem on an orphrey in **Regina**, a multi-coloured brocade. In white, beige, red, dark red, dark green or purple. Width 59"; length 49"; unlined, with inside stole. Each emblem available on all liturgical colours.

DUPION 70% man-made fibres and 30% viscose			3168
1-3168 \$ 1,395.00	7-3168 \$ 1,395.00	50-3168 \$ 395.00	34-3168 \$ 395.00
70-3168 \$ 2,075.00	71-3168 \$ 915.00	72-3168 \$ 840.00	
64-3168 \$ 930.00	62-3168 \$ 740.00	32-3168 \$ 220.00	31-3168 \$ 220.00
69-3168 \$ 660.00	60-3168 \$ 1,550.00 \$ 1,810.00		

SLABBINCK®



3361
\$ 1,395.00

3169
\$ 1,395.00



3170
\$ 1,395.00

3171
\$ 1,395.00

3362
\$ 1,395.00

3168
\$ 1,395.00

2750-0

Coordinated set of vestments and paraments in **Dupion**, knotted yarn dyed fabric, 70% man-made fibres and 30% viscose. Adorned with orphreys in **Regina**.

Available in white, beige, red, dark red, dark green and purple.

Chasuble.

Width 59", length 53"; unlined, with inside stole.

2749-4 Roll-collar "4", in velvet \$ 1,027.00

2750-0 Plain neck "0" \$ 1,450.00

2751-4 Roll-collar "4", in velvet \$ 2,955.00

2752-0 Plain neck "0" \$ 735.00

299-2749 Roman chasuble, lined \$ 2,035.00

Dalmatic.

7-2749 Dalmatic \$ 1,095.00

Benediction set.

70-2749 Cope, unlined, standard size 57" or custom-made \$ 1,655.00

71-2749 Humeral veil, lined, standard size 21 1/4" x 108" \$ 830.00

72-2749 Mitre; when ordering, please indicate head size \$ 905.00

Lectionary cover.

For the large or small lectionary, sacramentary and Book of Gospels.

Or indicate the type and dimensions; width (A), height (C) and depth (D).

35-2896 Lectionary \$ 355.00

Funeral pall.

Add dignity to the funeral service. Two sizes:

6' x 10', to cover the casket only.

8' x 12', to cover casket and carriage. Finished with rounded corners to prevent soiling of pall.

Fused backing included.

60-2749 6' x 10' \$ 1,395.00

60-2749 8' x 12' \$ 1,910.00



7-2749

2752-0

2749-4

2751-4



70-2749

71-2749

72-2749

299-2749 front



back



60-2749



35-2896



2749-0

50-2749



62-2749

In Dupion, fabric of 70% man-made fibres and 30% viscose.

With Regina orphreys and tassels.

- | | | |
|-----------------|----------------------------------------------------|--------------------|
| 2749-0 | Chasuble, width 59", length 53", with inside stole | \$ 870.00 |
| 7-2749 | Dalmatic | \$ 1,095.00 |
| 31-2749 | Chalice veil, 23" x 23", lined | \$ 225.00 |
| 32-2749 | Burse, 8" x 8" | \$ 225.00 |
| 34-2749 | Deacon stole, style 65 | \$ 500.00 |
| 50-2749 | Overlay stole, style 65 | \$ 500.00 |
| 62-2749 | Lectern cover, 18" x 71" | \$ 735.00 |
| 299-2749 | Roman chasuble, lined | \$ 2,035.00 |



7-2749

50-2749



62-2749

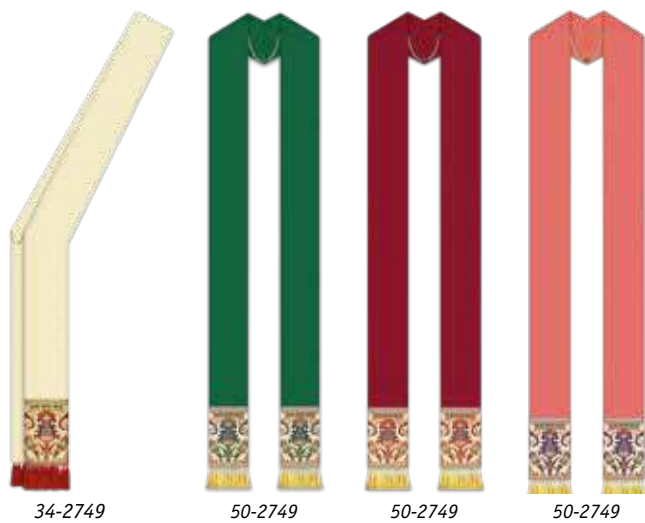

34-2749

50-2749

50-2749

50-2749



31-2749



32-2749



299-2749





2-3858

2-3858

2-3858

2-3858

In **Celtic**, fabric of 100% man-made fibres.
 Monastic chasuble, width 63", length 53"; with inside stole.
 Woven banding with *hand embroidered* cross motif in relief.
2-3858 Monastic chasuble, roll-collar "3" **\$ 1,335.00**

In **Duomo**, fabric of 100% man-made fibres.
 Velvet band with gold crosses and small braid.
 Chasuble width 63", length 53", with inside stole.
5257 Chasuble, roll-collar "4" **\$ 1,320.00**



5257

5257

5257

5257

72-19

1-19



Coordinated set of vestments and paraments. Manufactured in **Melchior**, 99% viscose and 1% gold threads, a yarn dyed, lightweight, colourful material, with randomly woven gold and colour threads. Without embroidery. In white, red, green or purple.

Chasuble, cope, dalmatic, mitre.

Width 63", length 53"; unlined, with inside stole.

- 1-19 Chasuble, low stand-up collar "6" \$ 781.00
- 1-19 Chasuble, plain neck "0" (not illustrated) \$ 685.00
- 7-19 Dalmatic, with small dalmatic stole, low stand-up collar "6" \$ 781.00
- 70-19 Cope, unlined; standard length 57" \$ 1,145.00
- 72-19 Mitre; when ordering, please indicate head size \$ 730.00

Overlay stole

Style 25: with flat capuche; interlined and selflined.

- 50-19 White, red, green or purple \$ 215.00
- 51-19 Reversible white-purple or red-green \$ 275.00

Altar paraments

Lectern cover; lined and interlined.

- 62-19 18" x 71", or custom-made \$ 465.00

Altar cover; lined and interlined.

- 64-19 36" x 75", or custom-made \$ 620.00

Laudian frontal; interlined.

A = length up to 71". D + C + E = depth plus front and back drops, up to 108".

- 66-19 Laudian frontal \$ 1,470.00

Half altar cover; lined and interlined.

A = length up to 71". D + C + E = depth plus front and back drops, up to 51".

- 113-19 Half altar cover \$ 675.00

Altar paraments; lined and interlined.

- 114-19 Altar paraments; 24" x 59", or custom-made each \$ 380.00

Important: when ordering an altar cover (64-19), a laudian frontal (66-19), a half altar cover (113-19), or altar paraments (114-19), please indicate sizes A, C, D and E of the finished item.

If longer or deeper than the indicated sizes, add a supplement per inch \$ 7.00

If measurement D + C + E is more than twice the width of the fabric (minus seam and hem): **price on request**

1-19

1-19

1-19



7-19

70-19

51-19

51-19



62-19

113-19

50-19



62-19

64-19

50-19



62-19

66-19

50-19



62-19

114-19

50-19

5306



3361



5034



3262



5289



5301



3950

50-5163

5162



5390

3262	Chasuble in Pius ; width 63", length 53", plain neck "0". With embroidered symbol of Our Lady	\$ 480.00
3361	Chasuble in Dupion ; width 59", length 49"; plain neck "0". With a hand embroidered emblem on an orphrey in Regina	\$ 1,395.00
3950	Chasuble in Cantate ; width 63", length 53"; roll-collar "4" in velvet. With a velvet band and embroidered symbol of Our Lady	\$ 1,990.00
5034	Chasuble in Cantate ; width 63", length 53"; with embroidered collar "6A". Hand embroidered symbol of Our Lady	\$ 1,985.00
5162	Chasuble in Cantate ; width 63", length 53"; roll-collar "4". With a velvet band and embroidered Marian emblem	\$ 3,300.00
50-5163	Overlay stole in Cantate ; style 25; hand embroidered Marian emblem, finished with blue velvet bands	\$ 1,015.00
5301	Chasuble in Duomo ; width 63", length 53"; plain neck "0". With beautiful damask and design of "Our Lady of Guadeloupe"	\$ 1,565.00
5306	Chasuble in Duomo ; width 63", length 53"; plain neck "0". With beautiful woven galoon	\$ 1,095.00
5289	Chasuble in Duomo ; width 63", length 53"; plain neck "0". With beautiful damask and design of Our Lady	\$ 1,565.00
5390	Chasuble in Duomo ; width 63", length 53"; roll-collar "4". With woven band and machine embroidered emblem	\$ 1,680.00

Cantate fabric composition has been changed: 61% wool, 6% lurex and 33% man-made fibres

All prices are for chasubles with inside stole.



Copes and mitres

When ordering, please indicate cope length. If not specified, standard length 57" will be provided. For mitres, specify head size. The copes are unlined and without underlay stole.

In **Brugia**, soft blended fabric of 100% wool.

In beige, red, dark green or purple.

Orphrey in **Ornata**, an elegant fabric with design woven in shades of gold colours.

70-3111 Cope \$ 1,755.00

72-3111 Mitre (not illustrated) \$ 920.00

Beautiful woven galoon in shades of gold colours.

70-3115 Cope \$ 1,890.00

72-3115 Mitre (not illustrated) \$ 1,050.00

Woven galoon with beautiful colour variations.

70-3120 Cope \$ 1,995.00

72-3120 Mitre (not illustrated) \$ 1,205.00

In **Cantate**, structured fabric with gold threads woven into the material, new composition fabric: of 61% wool, 33% man-made fibres and 6% lurex.

Hand embroidered on velvet banding; motif inspired by the Ursula Shrine by Memling.

70-2784 Cope \$ 4,060.00

72-2784 Mitre (not illustrated) \$ 1,535.00

In **Dupion**, fabric woven with knotted texture,

fabric of 70% man-made fibres and 30% viscose.

In beige, dark red, dark green or purple.

Orphrey in **Regina**, a multi-coloured brocade.

70-2749 Cope \$ 1,655.00

72-2749 Mitre \$ 905.00

In **Melchior**, 99% viscose and 1% gold threads, a

yarn dyed, lightweight colourful material, with

randomly woven gold and colour threads.

70-19 Cope \$ 1,145.00

71-19 Humeral veil, lined \$ 680.00

72-19 Mitre \$ 730.00

In **Cantate**, new composition fabric: of 61% wool,

33% man-made fibres and 6% lurex. Entirely hand

embroidered in cotton and gold threads.

Hand embroidered cross motif.

70-3569 Cope \$ 3,480.00

50-3569 Stole, style 25 \$ 675.00

72-3569 Mitre, in **Choral** \$ 1,390.00

Matching humeral veil available for all models.



Precious vestments in Cantate, new composition: fabric of 61% wool, 33% man-made fibres and 6% lurex (gold threads).

A special collection of vestments in which the depth of religious expression is reflected in the quality of fabric and the harmony of colours.



- Cross motif, hand embroidered in cotton and gold threads.
 Chasuble, width 63", length 53"; with inside stole; with embroidered collar.
- 3569** Chasuble, with roll-collar "4" **\$ 2,405.00**
 - Overlay stole, style **25**: with flat capuche.
 - 50-3569** Matching overlay stole **\$ 675.00**
 - Deacon stole, style **34**: worn from left shoulder to right hip.
 - 34-3569** Matching deacon stole **\$ 495.00**
 - 70-3569** Matching cope, unlined; indicate length when ordering **\$ 3,480.00**
 - 72-3749** Matching mitre in **Choral**; indicate head size **\$ 1,500.00**



- Chasuble with scenes from the Life of Jesus, three on front and three on back.
- 2747** With roll-collar "4" **\$ 3,545.00**
 - "Four Evangelists".
 - 3-3568** Chasuble with overlay stole **\$ 2,707.00**
 - 1-63 Plain chasuble only, roll-collar "4"; without inside stole **\$ 882.00**
 - 50-3568 Overlay stole only, style **38** in **Choral** **\$ 1,825.00**



- Beautiful variation on the cross motif, hand embroidered; with embroidered collar.
- 3824** Chasuble, with embroidered roll-collar "4" **\$ 2,265.00**
 - 7-3824** Dalmatic, with embroidered roll-collar "4" **\$ 3,205.00**
 - 70-3569** Cope **\$ 3,480.00**



- Hand embroidered band on front and back, roll-collar "4".
- 3356** Lamb of God **\$ 1,975.00**
 - Matching hand embroidered overlay stole, style **38**: with tapered flat capuche. Width 6", total length 59".
 - 50-3356** Lamb of God **\$ 1,060.00**



Overlay Stole

Style 25: with flat capuche.

- Manufactured in white **Dupion**, 30% viscose, 70% man-made fibres. Machine embroidery, available in other languages.
- 50-5349** Lord's Prayer and cross, style 25 \$ 400.00
- Manufactured in **Lucia**, rustic fabric with textured structure, 53% man-made fibres, 31% cotton, 16% viscose.
- 50-3799** Lamb and Chiro symbol \$ 440.00
- 50-3800** Symbol of Our Lady \$ 440.00
- 50-3801** Symbol of the Cross \$ 440.00
- 50-3802** Weddings \$ 440.00
- 50-3803** Symbol dove and rainbow \$ 440.00
- 50-3804** Baptisms \$ 440.00
- 50-3805** Christmas \$ 440.00
- 51-3806** Reversible white-purple or red-green, cross symbol \$ 390.00
- 50-3807** Red, Holy Spirit \$ 440.00
- 50-3808** Green for Eucharist \$ 440.00
- 50-3809** Green for Eucharist \$ 440.00
- 50-3810** Purple for Advent \$ 440.00
- 50-3811** Purple for Lent \$ 440.00

- Manufactured in **Melchior**, a yarn dyed, colourful material with woven gold and colour threads.
- 50-19** White, red, green or purple \$ 215.00
- 51-19** Reversible white-purple or red-green (not illustrated) \$ 275.00

Style 75: with stand-up collar.

In **Omega**, yarn dyed fabric structured texture.

With combination of colourful applique and embroidery in gold and colour thread.

- 51-2605** Reversible white-purple or red-green \$ 410.00
- 51-259** Reversible white-purple (not illustrated) or red-green \$ 405.00

Only available in the fabrics, designs and colours as shown. Woven in **Gobelin**, a fabric of 100% viscose. "Life of the Blessed Mother", with illustrations from the "Annunciation" to the "Assumption" (3309).

"Twelve Apostles", illustration of the twelve apostles with Latin names (3359).

Style 38: with tapered flat capuche. Width 5½", total length 59".

- 50-3309** "Life of the Blessed Mother" Booklet with explanation of each individual scene included. \$ 485.00
- 50-3359** "Twelve Apostles" \$ 485.00

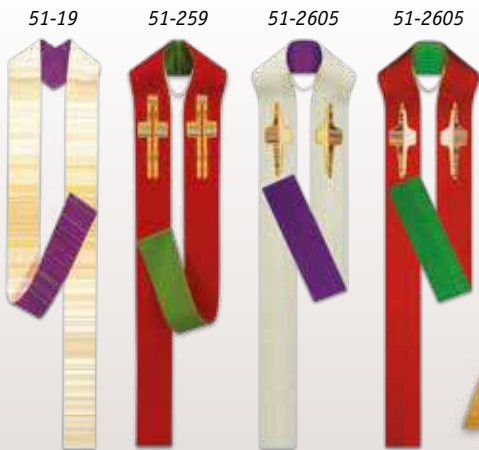
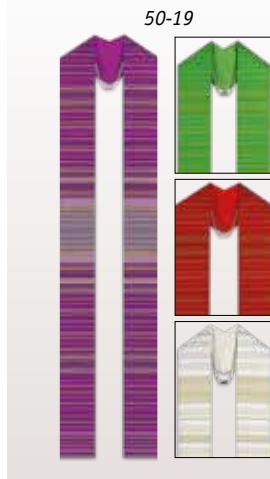

All illustrated overlay stoles can be made as deacon stoles. Please contact your local dealer for additional information.

Vestment hanger

Ideal to hang chasuble, dalmatic, cope, humeral veil, stole, lectern cover or superfrontal.

The horizontal bar has etched lines to prevent sliding.

- 561** Wooden vestment hanger, 1" thick, 23" wide; with metal hook \$ 23.25



278-5018



278-25

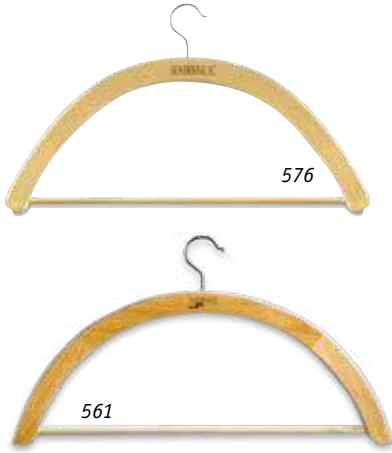

576

561

Vestment hanger. Ideal to hang chasuble, dalmatic, cope, humeral veil, stole, lectern cover or superfrontal. With metal hook.

561 Solid wood; 1" thick, width 23"

\$ 23.25

F 576 Wood-tone resin material; 3/8" thick, width 23", with fixed metal hook

\$ 18.95



155

165

Amice. Fits the neck perfectly.

With velcro in front to adjust size; and embroidered cross in back of neck. Choice of fabrics, please contact your local dealer.

155 Amice, embroidered cross in neck **\$ 85.00**

With stand-up collar, velcro closure in back. Available in standard size (fits shirt size to 17) and large (fits size 17 to 19). Extra large, price upon request. If the size is not specified, standard will be supplied. Should your order not specify any preference of fabric, we will supply the amice in **Tertenka**, white.

165 Amice **\$ 85.00**

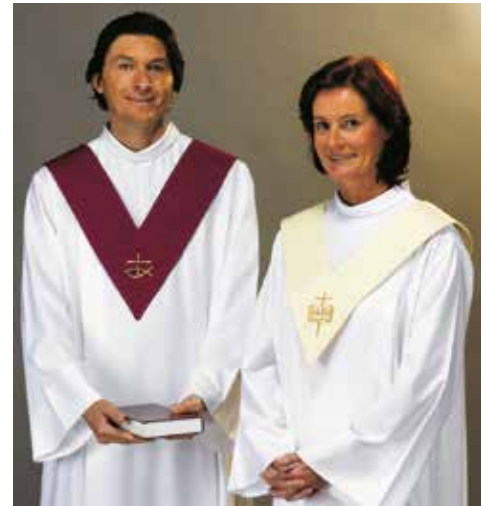

278-3557

278-3581

Scapular

Can be worn over a liturgical gown or lay clothes. Style **278** neckline with small capuche, width 4".

• In **Dupion**, fabric of 70% man-made fibres and 30% viscose.

278-25 Without embroidery **\$ 168.00**

278-25 Reversible white/purple or red/green **\$ 205.00**

278-3557 Embroidered Ictus motif **\$ 178.00**

278-3581 Embroidered Alpha-Omega motif **\$ 185.00**

• In **Pius** of 100% man-made fibres.

278-5018 Rainbow colours **\$ 295.00**



Cord with hand-made tassel

In rayon (dry clean), a carabiner to hang the cross and to adjust the height of the tassel, length 24". Price, without wooden cross.

3647 (white), **3648** (green),

3649 (gold-yellow), **3650** (blue),

3651 (red), **3652** (purple),

3653 (beige)

\$ 7.75

4614 Small wooden cross, ht. 4 3/8", with ring

\$ 2.70



57-0

57-1

Rope cincture for albs

• In washable cotton; with hand-made knot; in flax, white, red, green (57-0, 57-1), dark green (157-0, 157-1), purple, blue, gold or black.

Thin cincture (3/8" not illustrated).

157-0 Length 147"

\$ 16.75

157-1 Length 81"

\$ 14.00

Standard cincture (1/2").

57-0 Length 147"

\$ 24.50

57-1 Length 81"

\$ 17.50



703-0

703-1

• In rayon (dry clean); with hand-made tassel. All colours except black.

703-0 Length 147", tassel 4" included

\$ 22.50

703-1 Length 81", tassel 4" included

\$ 21.00



7-2749

7-19



7-5291



7-5148



- In **Dupion**, fabric of 70% man-made fibres and 30% viscose, width 59", length 53".
- 7-2749 Dalmatic, with galloon in **Regina** \$ 1,095.00
- 7-5148 Dalmatic, with galloon \$ 830.00
- 7-5149 Dalmatic, with galloon \$ 980.00
- 7-5150 Dalmatic, with hand embroidery \$ 870.00
- In **Melchior**-fabric, 99% viscose and 1% gold threads; width 63", length 53"; white, red, green or purple.
- 7-19 Dalmatic, low stand-up collar "6" \$ 781.00
- In **Duomo**, 100% man-made fibres, with beautiful woven galloon; width 63", length 53".
- 7-5291 Dalmatic, style IV \$ 1,360.00
- In **Brugia**, of 100% wool; width 59", length 53".
- Band in **Ornata**.
- 7-3111 Dalmatic, roll-collar "4" \$ 1,205.00



7-3358



7-3120



7-2749

- Combination of brocade application and orphreys.
- 7-3120 Dalmatic \$ 1,510.00
- Banding and decoration around neck in damask fabric, bordered with gold braid; adorned with hand embroidered cross.
- 7-3358 Dalmatic \$ 1,540.00
- In **Pius**, fabric of 100% man-made fibres; width 63", length 53".
- 7-3576 Dalmatic, with galloon \$ 450.00
- 7-5033 Dalmatic, with galloon and embroidered cross in gold threads \$ 485.00

Small dalmatic inside stole included with all dalmatics.

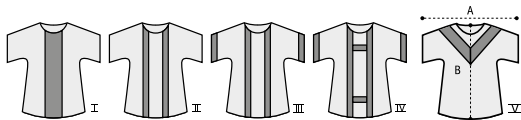

7-5149



7-5033



7-5150



7-3111



7-3576



34-4739 34-2752 34-19 34-2605 34-3277 34-3799 34-5292 34-3219 34-5347

Deacon stoles, style 34: worn from left shoulder to right hip.

• With hand embroidery.
34-5292 Duomo \$ 1,140.00

• With motifs woven into the fabric.
34-19 Reversible stole, in Melchior \$ 275.00
34-2752 Regina \$ 680.00
34-3110 Ornata \$ 315.00
34-3377 Regina \$ 560.00

• With a combination of applique and embroidery in gold- and wool thread. Front motif at chest height, back motif on lower panel.
34-2511 Omega \$ 545.00
34-2605 Reversible stole, Omega \$ 410.00
34-3358 Brugia \$ 440.00
34-3799 Lucia \$ 440.00
34-3811 Lucia \$ 440.00
34-3809 Lucia \$ 440.00
34-4739 Lucia \$ 635.00

• With machine embroidery.
34-3275 Dupion \$ 295.00
34-3277 Dupion \$ 295.00
34-3278 Dupion \$ 295.00
34-3553 Dupion \$ 250.00
34-5347 Dupion, Lord's prayer and cross \$ 400.00

• With ophrey.
34-5290 Duomo \$ 295.00
34-3219 Brugia \$ 380.00
34-3552 Dupion \$ 400.00

• All deacon stoles in this catalogue can be made as overlay stoles and can also be made as reversible stoles: price on request.



34-3275 34-3552 34-3358 34-2511 34-19 34-3809

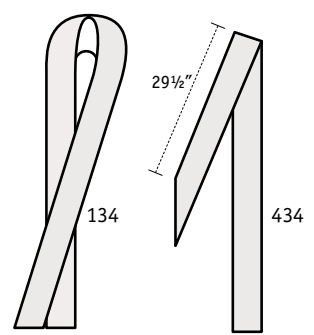
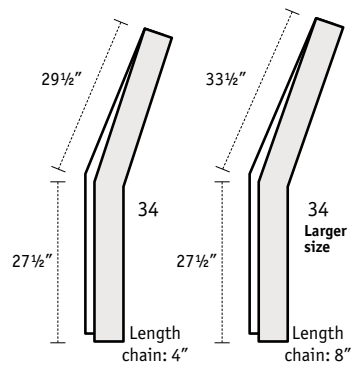

34-3278 34-3110 34-5290 34-3553 34-3811 34-3377

Lucia-fabric, 53% man-made fibres, 31% cotton and 16% viscose or **Dupion**, fabric of 70% man-made fibres and 30% viscose, applique with gold and wool embroidery.

Chasuble, width 59", length 53"; with inside stole.

Overlay stole, style 25: with elegant chain at the back to support flat capuche.

Lectern cover. Standard size : 18" x 71", or custom-made. Interlined and selflined.

Altar cover. Standard size : 36" x 75", or custom-made. Interlined and selflined.

		Lucia	Dupion
5266	Chasuble	\$ 1,395.00	
50-5267	Overlay stole	\$ 805.00	
62-5268	Lectern cover	\$ 935.00	
64-5269	Altar cover	\$ 1,345.00	

3173	Chasuble, low stand-up collar "6"	\$ 975.00	\$ 821.00
50-2529	Overlay stole	\$ 445.00	\$ 425.00
62-2530	Lectern cover	\$ 740.00	\$ 685.00
62-2531	Lectern cover	\$ 740.00	\$ 685.00
64-2532	Altar cover	\$ 1,140.00	\$ 965.00

3174	Chasuble, low stand-up collar "6"	\$ 975.00	\$ 821.00
50-2534	Overlay stole	\$ 445.00	\$ 425.00
62-2535	Lectern cover	\$ 740.00	\$ 685.00
62-2536	Lectern cover	\$ 740.00	\$ 685.00
64-2537	Altar cover	\$ 1,140.00	\$ 965.00

2170	Chasuble, roll-collar "4"	\$ 1,335.00	\$ 1,125.00
50-2171	Overlay stole	\$ 660.00	\$ 630.00
62-2172	Lectern cover	\$ 940.00	\$ 835.00
62-2173	Lectern cover	\$ 940.00	\$ 835.00
64-2174	Altar cover	\$ 1,345.00	\$ 1,085.00

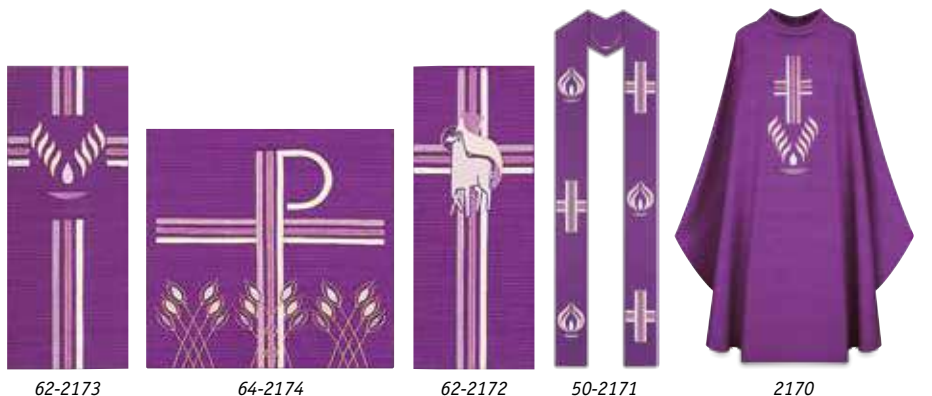
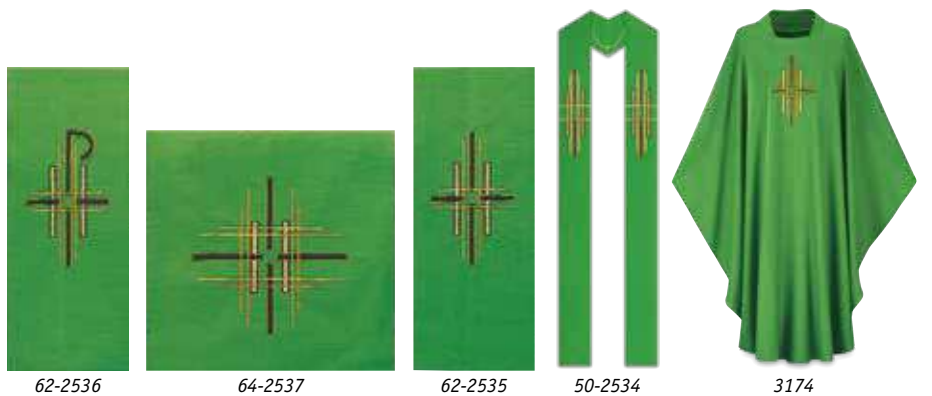
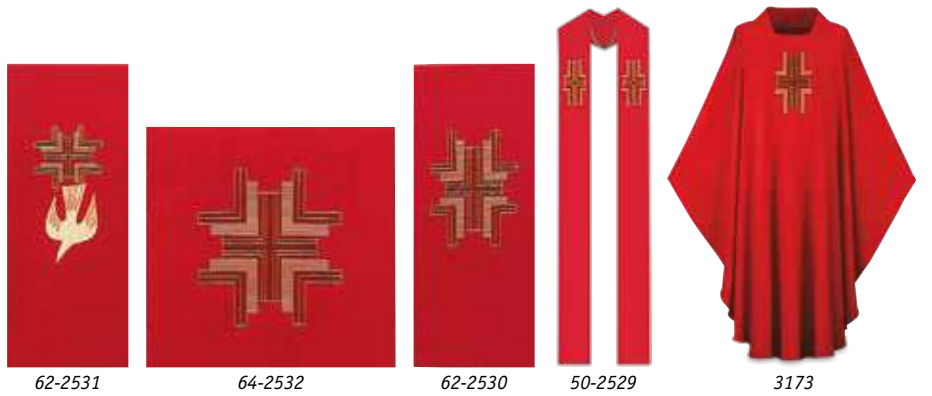

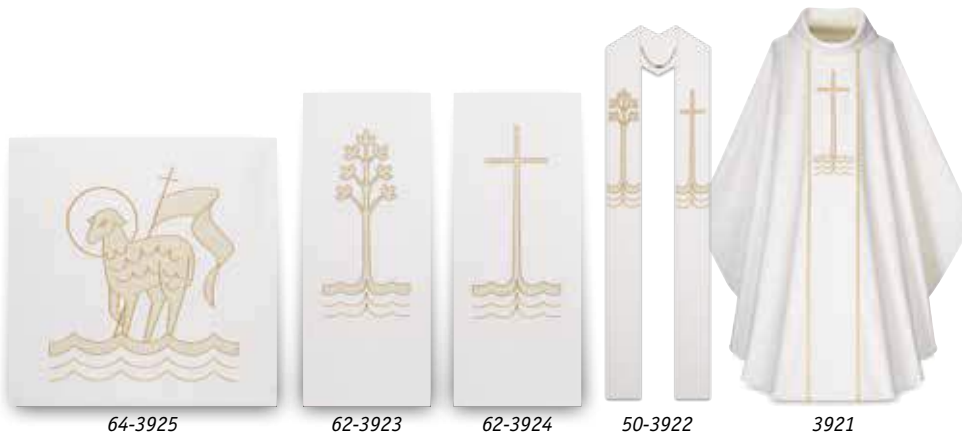

64-3925

62-3923

62-3924

50-3922

3921

Exceptional collection of vestments and paraments, adorned with an exquisite application in delicate colour combination with embroidery in gold and wool threads. In **Lucia**, rustic fabric with textured structure, 55% man-made fibres, 31% cotton, 16% viscose. White, red, dark green or dark purple.

• **Chasuble**, width 59", length 53", unlined, with inside stole.
3921, 3926, 3931 or
3936 With roll-collar "3" **\$ 1,480.00**

• **Overlay stole**. Style 25: with elegant chain at the back to support flat capuche.
50-3922, 50-3927, 50-3932 or
50-3937 Overlay stole **\$ 515.00**

• **Lectern cover**. Standard size : 18" x 71", or custom-made. Interlined and selflined.
62-3923, 62-3924, 62-3928, 62-3929, 62-3933, 62-3934, 62-3938 or
62-3939 Lectern cover **\$ 830.00**

• **Altar cover**. Standard size : 36" x 75", or custom-made. Interlined and selflined.
64-3925, 64-3930, 64-3935 or
64-3940 Altar cover **\$ 1,300.00**

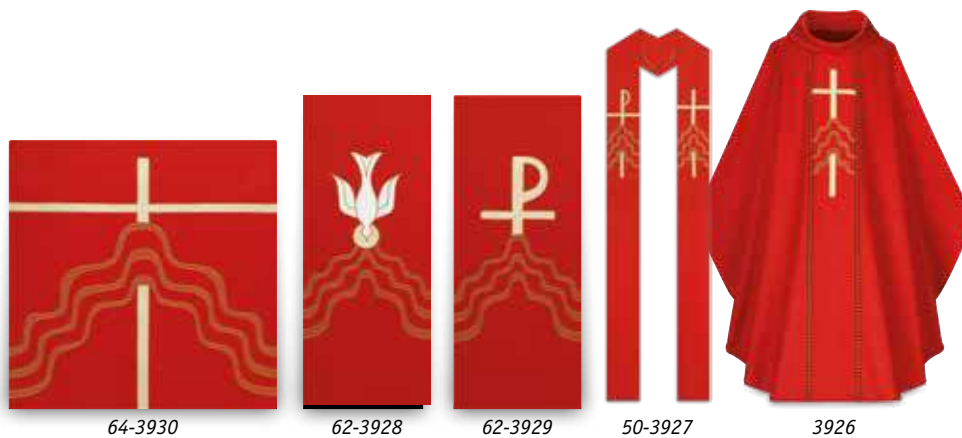

64-3930

62-3928

62-3929

50-3927

3926



64-3935

62-3933

62-3934

50-3932

3931



64-3940

62-3938

62-3939

50-3937

3936



Printed banner

In 100% man-made fibres.
 Height 9'6", width 3'4". Finished at top with open hem; with wooden rod, 2 wooden apples and hanging cord. Metal dowel at bottom, incorporated into hem.

In **Raytex**

7111 - 7155 Per banner \$ 188.00

In **Deco**

7505 - 7635 Per banner \$ 188.00

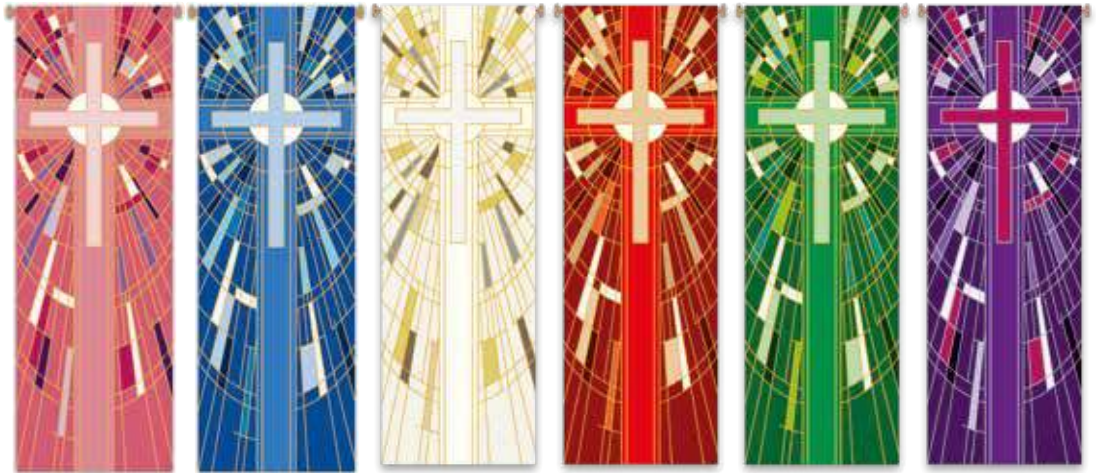

7509

7510

7505

7506

7507

7508



7511

7512

7513

7514

7515

7516

7517

7518

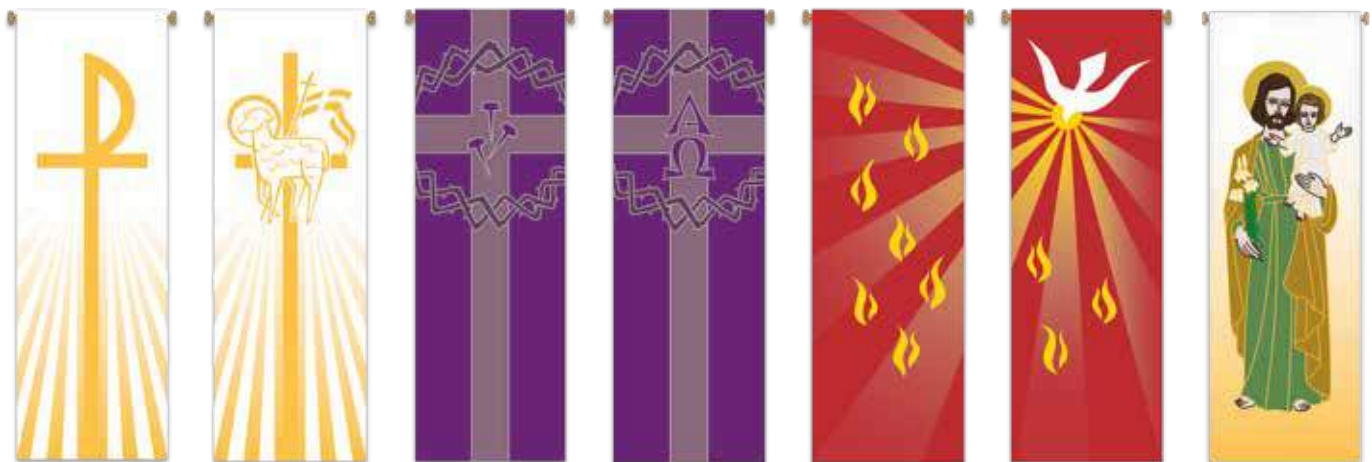

7148

7649

7154

7155

7150

7151

7524



7144

7635

7634

7111

7612

7117

7118

7622

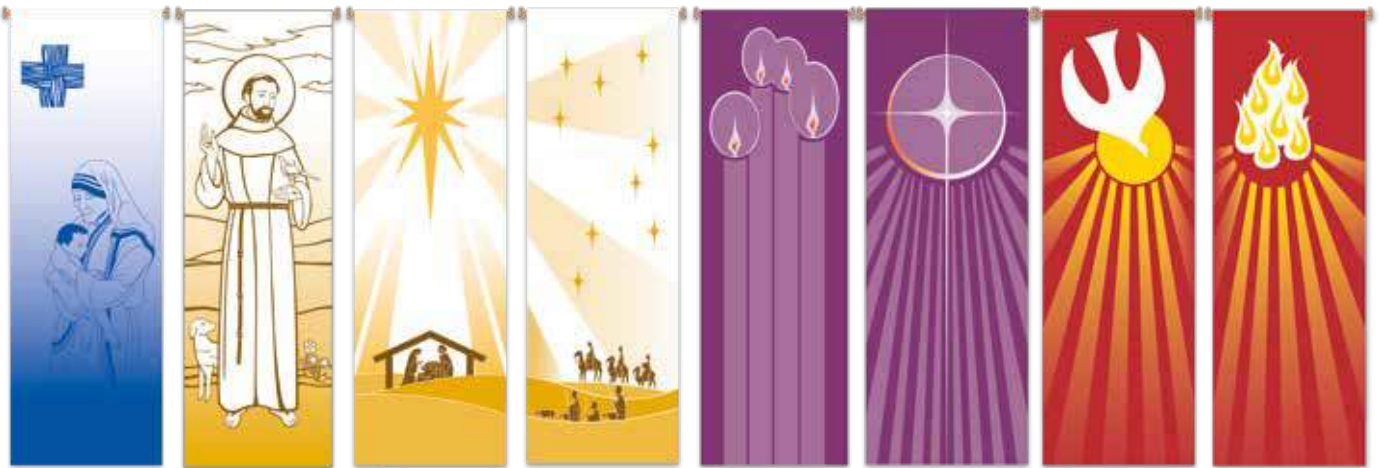

7631

7147

7626

7629

7619

7620

7115

7616

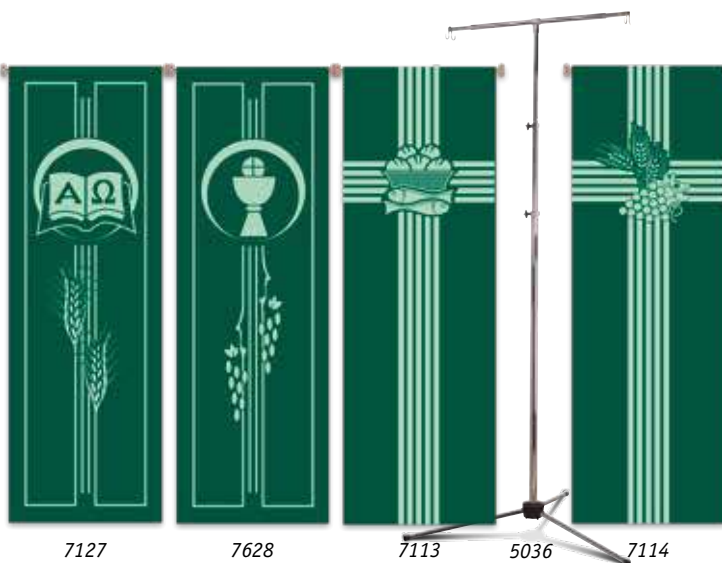

7127

7628

7113

5036

7114

Banner stand

For almost any type of banner or tapestry. Metal stand, completely chrome-plated with weighted base. Telescoping shaft, extends 70" to 177". Telescoping cross arm, extends 28" to 54", with double hook so that a banner can be hung in front and back.

5036 Adjustable in height and width **\$ 535.00**



7152

7153



7226



7229



7217



7918



7211



7912

Small inside banners

In response to your many requests, select screen printed banners are now available in a smaller size.

Perfect for offices, meeting rooms, small chapels, classrooms, etc.

The banners create a warm atmosphere, inspiring peace, quiet and prayer.

In Raytex DM, 100% man-made fibres.

Size 48" long by 24" wide.

Finished at top with open hem; wooden rod with two wooden apples, and hanging cord.

Metal dowel at bottom, incorporated into the hem.



7215



7216



7220



7219



7213

7214



5047

Banner stand

For almost any type of banner. Metal stand, completely chrome-plated with weighted base. Telescoping shaft, adjustable in height, extends 60" to 93", with hook on front and back, so two banners can be hung at the same time.

5047 Banner stand \$ 350.00

- 7211 Lamb of God \$ 107.00
- 7912 Chiro, Monogram of Christ \$ 107.00
- 7213 Eucharist, bread with Cross and Ichthus (fish) \$ 107.00
- 7214 Eucharist, with wheat design and grapevine \$ 107.00
- 7215 Holy Spirit \$ 107.00
- 7216 Flames \$ 107.00
- 7217 Lent, crown of thorns \$ 107.00
- 7918 Lent, nails and shroud \$ 107.00
- 7219 Advent, candle \$ 107.00
- 7220 Advent, star \$ 107.00
- 7226 Christmas \$ 107.00
- 7229 Christmas \$ 107.00



Chasuble with digital printed bands in **Deco**-fabric.
 In **Pius**-fabric, 100% man-made fibres, white, red green or purple.
 Width 63", length 53", with inside stole.
7505, 7506, 7507, 7508 Chasuble **\$ 525.00**
 In **Dupion**, 70% man-made fibres, 30% viscose; rose or blue.
 Width 59", length 53", with inside stole
7509 or **7510** in **Dupion** Chasuble **\$ 575.00**

In **Deco**-fabric, 100% polyester. Digital printed design.
 Overlay stole, style **25**.
50-7505, 7506, 7507, 7508, 7509 or **7510** Overlay stole **\$ 325.00**

Altar cover 35½" x 75", drop 35½"
864-7505, 7506, 7507, 7508, 7509 or **7510** Altar cover **\$ 185.00**
 Lectern cover 18" x 71", drop 43"
862-7505, 7506, 7507, 7508, 7509 or **7510** Lectern cover **\$ 112.00**
 Banner width 3¼', height 9¾'
766-7505, 7506, 7507, 7508, 7509 or **7510** Banner **\$ 188.00**

Banner stand
5036 Adjustable in ht 70" to 177" and width 28" to 54" **\$ 535.00**



Full laudian frontal

A laudian frontal covers the altar on all sides. The fabric is reinforced with fused backing material and has rounded corners; the hem is finished with a ribbon on the inside. The side drops (D and E) are of equal length.

Available either without embroidery or with an exquisite combination of colourful applique and embroidery in gold and wool threads.

For altar with length (A) up to 71".

Manufactured in **Omega**-fabric or **Lucia**-fabric.

Maximum depth (D + C + E)	up to 101"	up to 110"
Fabric	Omega	Lucia
66 Without embroidery	\$ 1,460.00	\$ 1,230.00
66-3242, 66-3256, 66-3434, 66-3629	\$ 2,095.00	\$ 1,810.00
66-2901	\$ 2,335.00	\$ 2,055.00

Manufactured in **Dupion**-fabric.

66-3142 Adorned with orphreys in **Regina**

Dupion
\$ 1,420.00

Manufactured in **Regina**, a multicoloured brocade.

66-2752

Regina
price upon request

If longer or deeper than indicated measurements **price upon request**

If measurement D + C + E is more than 2 x the width of the fabric minus seam and hem **price upon request**

Important

When ordering, please indicate measurements of finished laudian cover:

A = length of mensa;

C = depth of mensa;

D and E = equal front, back and side drops, usually 2" less than altar height.

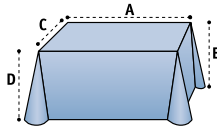

Lectern cover

Fabric
62-3241, 62-3254, 62-3630, 62-3631, or
62-3635 Lectern cover, 18" x 71"

	Omega	Lucia
	\$ 800.00	\$ 745.00

62-3143 Lectern cover, 18" x 71", in **Dupion**

Dupion
\$ 770.00

62-2752 Lectern cover, 18" x 71", in **Regina**

Regina
\$ 760.00



4756 - Custom-made, price on request.



Tapestries, lectern and altar covers

To adorn any room or hall, to be hung on a Paschal candlestick, or to be used as a processional banner, lectern cover or altar cover.

Each of these tapestries is a unique creation of our Flemish artists. They create a warm atmosphere, inspiring quiet and prayer. We can design tapestries inspired by the most diverse sources, giving expression to your ideas; for example, with the Patron Saint of your church or institution, or completely custom-made as shown on top of this page. They are processed with the utmost artistic skill and care, manufactured in fabric with pronounced structure, lined and interlined, with a fine combination of colour applique with gold and wool thread embroidery. Top and bottom are finished with an open hem to hold rod. The loops and fringes are available at extra charge and are not included in the sizes.

A hanging rod with two supports only supplied for sizes 31½" x 12½" and 47" x 18".



Unit price for standard sizes.						
Price cat.	Tapestries				Lectern cover	Altar cover
	31½" x 12½"	47" x 18"	59" x 35"	110" x 43"	18" x 71"	36" x 75"
B	\$ 565.00	\$ 855.00	\$ 1,885.00	\$ 3,125.00	\$ 970.00	\$ 1,570.00
C	\$ 685.00	\$ 1,080.00	\$ 2,175.00	\$ 3,600.00	\$ 1,250.00	\$ 1,700.00
D	\$ 920.00	\$ 1,295.00	\$ 2,670.00	\$ 3,910.00	\$ 1,435.00	\$ 1,960.00
E	\$ 1,295.00	\$ 1,685.00	\$ 3,075.00	\$ 4,680.00	\$ 1,840.00	\$ 2,650.00

Tapestries available with loops and fringes, price on request.



Washable in coat style

The garment is adapted for use under a chasuble, as a vestment for concelebration, for baptism, home Mass or for lectors.

For all styles:

- Convenient coat style. The collar finished with fixed amice, concealing clothing underneath (no separate amice needed).
- With fabric-covered buttons for perfect fit.
- Two elegant front and back pleats guarantee complete freedom of movement.
- The style for men: has two slits for access to trousers pockets.
The style for women: has 2 pockets.
- May be worn with or without cincture.
- Manufactured in wash-and-wear fabrics.

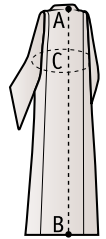

- Style without decoration; please specify choice of fabric.

Style 11: choice of plain fabrics.

11 Athos , grey	\$ 495.00
11 Brugia , <i>only white</i>	\$ 810.00
11 Greco , beige	\$ 495.00
11 Jersey , white	\$ 495.00
11 Leo , flax-white	\$ 495.00
11 Livorno , 45% wool; white, beige or black	\$ 695.00
11 Pius , white, beige or off-white	\$ 395.00
11 Prisma , 45% wool; white	\$ 675.00
11 Ravenna , white	\$ 550.00
11 Terlenka , white, black and other colours	\$ 495.00
11 Vaticano , beige	\$ 495.00

Standard sizes

When ordering, please indicate length A-B: from base of the neck to top of shoe (usually approx. 12" less than person's height).

Neck size for sizes **Slim** and **Regular**: 16½".

Neck size for sizes **Large** and **XLarge**: 18".

MEN	Chest C			
	length A-B	37" slim	41" regular	45" large
55"	SK	MK	LK	50
57"	0	2	5	51
59"	1	3	6	52
61"	8	4	7	53
63"	SG	MG	LG	54

LADIES	Chest C (in inches)	Size
length A-B		
51"	31-34	L6
52"	31-34	L8
53"	34-37	L10
53"	37-41	L11
54"	34-37	L12
54"	37-41	L13
55"	37-41	L14
57"	41-45	L15
59"	45-49	L16

Should your order not specify (C), regular (41") for men and (34"-37") for ladies will be supplied.

Special sizes

Supplement for special sizes:

- only length A-B or sleeve length adjustments **\$ 40.00**
- entirely custom-made **\$ 135.00**



95 - Vaticano



195 - Livorno



44 - Vaticano



Athos-37



Jersey-53



Greco-77



Leo-70



Livorno-20

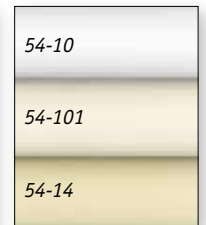

Pius-54



Prisma-26



Ravenna-87

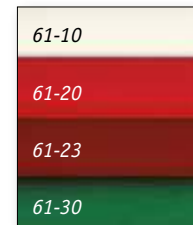

Terlenka-61

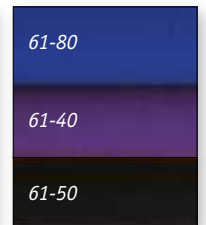

Washable gown, sanctuary alb

Manufactured in easy-to-laundry, wash-and-wear fabrics.

Standard lengths are: 55", 57", 59", 61" or 63".

Prices each for standard sizes.

Washable liturgical gown.

Particularly full and ample cut with wide sleeves (23³/₁₆"). Monastic style; garment is pulled over the head.

In two styles:

style 95: with deep hood;

style 195: with roll-collar.

95 or 195 Leo, flax-colour \$ 575.00

95 or 195 Livorno, 45% wool, white, beige or black \$ 895.00

95 or 195 Pius, white, beige or off-white \$ 475.00

95 or 195 Vaticano, beige \$ 575.00

Washable sanctuary alb.

Neck finish with roll-collar in front and capuche at the back. Monastic style; garment is pulled over the head. Wide sleeves (13") and slits to the trousers pockets.

Style without decoration.

44 Athos, grey \$ 495.00

44 Greco, beige \$ 495.00

44 Jersey, white \$ 495.00

44 Leo, flax-white \$ 495.00

44 Livorno, 45% wool, white, beige or black \$ 695.00

44 Pius, white, beige or off-white \$ 395.00

44 Prisma, of 45% wool, white \$ 675.00

44 Ravenna \$ 550.00

44 Terlenka, all colours \$ 495.00

44 Vaticano, beige \$ 495.00

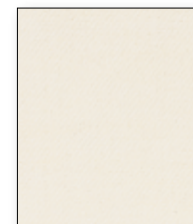

Vaticano-67



63-5189 (60)

Easy care altar cloths

For main and side altars, always custom-made and finished with 1½" hem. Fabric is added to the finished size for shrinkage at first laundering. Prewash is possible if required.

Supplement for prewash: \$ 15.50

Price per yard of altar cloth only, according to the total length.

In **Blended Linen**, preshrunk, white fabric of 55% linen and 45% man-made fibres. Easy to launder (wash, lukewarm).

- 63-38** Total depth up to 40" \$ 101.00/y
- Total depth up to 67"; no seam \$ 150.00/y
- Total depth up to 80"; no seam \$ 185.00/y

63-5189 Available in 4 colours: gold (60), red (20), green (30) or purple (40). Should your order not specify colour of embroidery, gold (60) will be supplied.

- Supplement:
- Total depth up to 40" \$ 136.00
 - Total depth up to 55" (=maximal depth), a minimum drop of 8" is needed \$ 187.00

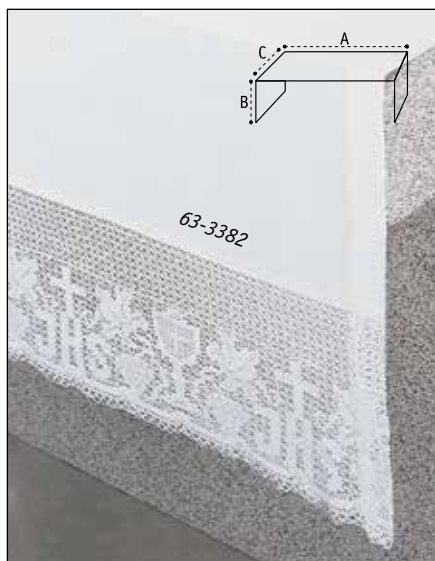

63-38

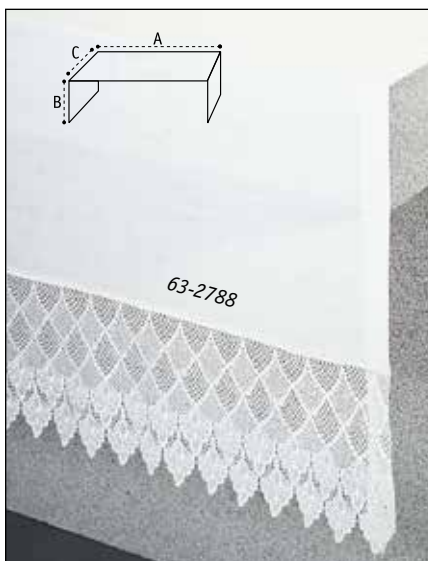

63-38

Please add to the price of the altar cloth 63-38.

63-2774 Washable embroidery in gold threads, "ALLELUIA" and 2 crosses, on front drop (D), minimum height (D) = 10"; supplement \$ 150.00

63-2788 Both side drops (B), with lace (h. 10"), in man-made fibres, per yard supplement (according 2 times the total depth C) \$ 109.00

63-3134 With elegant linear embroidery with crosses on both side drops (B). Minimal height (B) = 12". Supplement: Total depth up to 40" \$ 205.00; Total depth up to 67" \$ 235.00; Total depth up to 80" \$ 265.00

63-3382 Both sides (B) in lace (h. 11") 100% cotton; per yard supplement (according 2 times the total depth C) \$ 109.00/y

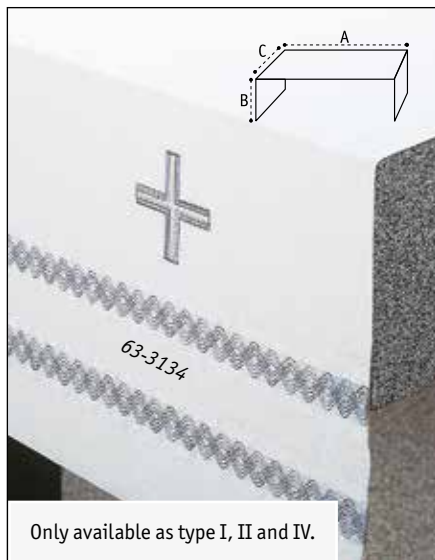

Only available as type I, II and IV.

63-38

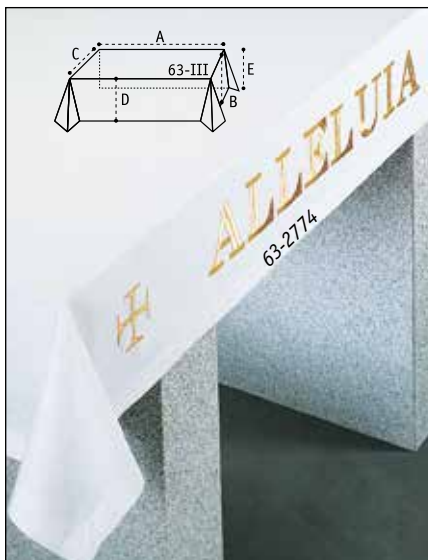

63-38

Easy care altar cloths

These easy to maintain altar cloths for main and side altars are always custom-made. Finished with 1½" hem.

Fabric is added to the finished size for shrinkage at first laundering. Prewash is possible if required. **Supplement for prewash: \$ 15.50.**

When ordering we require following data:

- ❶ type I, II, III or IV;
- ❷ dimensions; please indicate size of finished altar cloth according to "types" hereunder;
- ❸ fabric and price per yard of finished altar cloth.

❶ TYPES

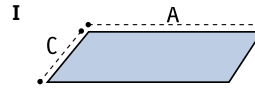

Covering altar mensa only.

Total length = A
Total depth = C

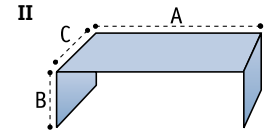

Covering altar mensa, with side drops.

Total length = A + 2 x B
Total depth = C

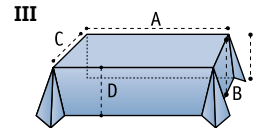

With square corners (tablecloth style), with front, side and back drops.

Total length = A + 2 x B
Total depth = C + D + E

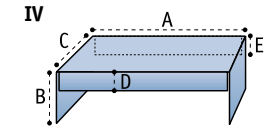

Covering altar mensa, with side drops and shorter front and/or back drop, with seam.

Total length = A + 2 x B
Total depth = C + D or C + D + E

❷ DIMENSIONS

- A = length of mensa
- B = side drops
- C = depth of mensa
- D = front side drop
- E = short back drop

❸ **FABRIC AND PRICE PER YARD** of finished altar cloth. Minimum charge one yard per cloth. All per yard prices include 1½" hem. Information: see above. Type IV, **extra charge 10%**.



63-38 Blended Belgian linen: plain white preshrunk fabric of 55% linen and 45% man-made fibres. Wash, lukewarm.
Total depth up to 40", price per yard **\$ 101.00** finished.
Total depth up to 67", price per yard **\$ 150.00** finished; no seam.
Total depth up to 80", price per yard **\$ 185.00** finished; no seam.



63-41 Basilica: made in blended Belgian linen (see 63-38), with inserted woven border on all 4 sides. Wash, lukewarm.
Total depth up to 48", price per yard **\$ 171.00** finished.
Total depth up to 73", price per yard **\$ 255.00** finished; no seam.



Only available as type I, II and IV.

101 Domus: made of blended Belgian linen (see 63-38), with washable embroidery and stitched pleats (7") on both side drops, in (10) white or (59) grey. When ordering, please specify embroidery colour. Wash, lukewarm.
Total depth up to 40", price per yard **\$ 101.00** finished; plus **\$ 102.00** for embroidery.
Total depth up to 67", price per yard **\$ 150.00** finished; plus **\$ 154.00** for embroidery; no seam.

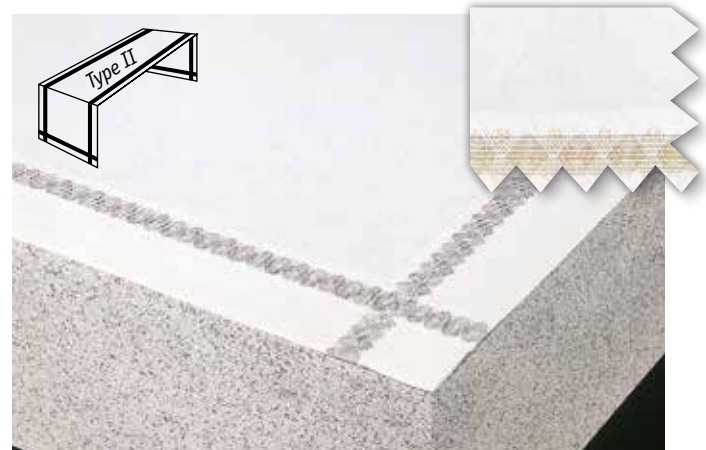

301 Cathedral: made of blended Belgian linen (see 63-38), with washable embroidery on all four sides in (59) grey/white or (60) gold metallic/white. When ordering, please specify embroidery colour. Should your order not specify colour, grey/white embroidery will be supplied. Wash, lukewarm.
Total depth up to 40", price per yard **\$ 164.00** finished; embroidery included.
Total depth up to 67", price per yard **\$ 240.00** finished; embroidery included; no seam.

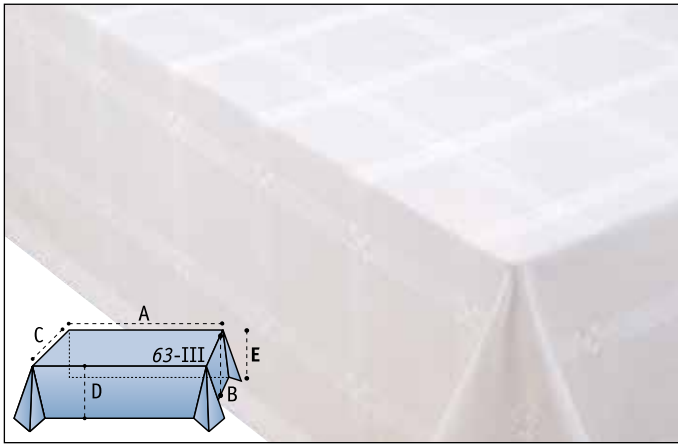

63-35 Alpha: white fabric with woven crosses, of 95% cotton and 5% linen. Wash, hot water.
 Total depth up to 53", price per yard \$ 137.00 finished.
 Total depth up to 85", price per yard \$ 205.00 finished; with seam.

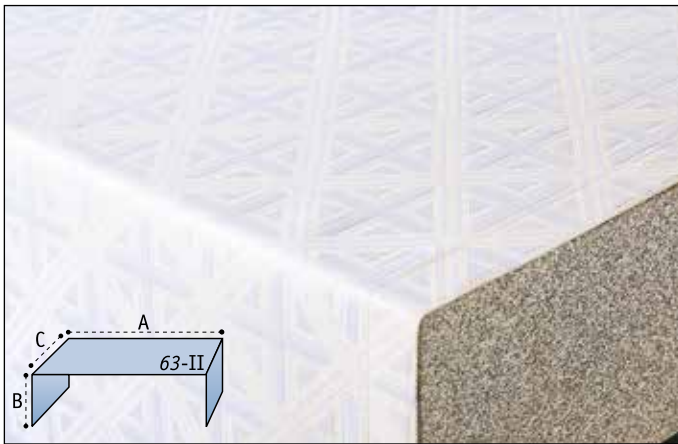

63-85 Crux: white jacquard weave of 85% man-made fibres and 15% cotton, with woven cross motifs. Wash, lukewarm.
 Total depth up to 51", price per yard \$ 122.00 finished.
 Total depth up to 82½", price per yard \$ 185.00 finished; with seam.

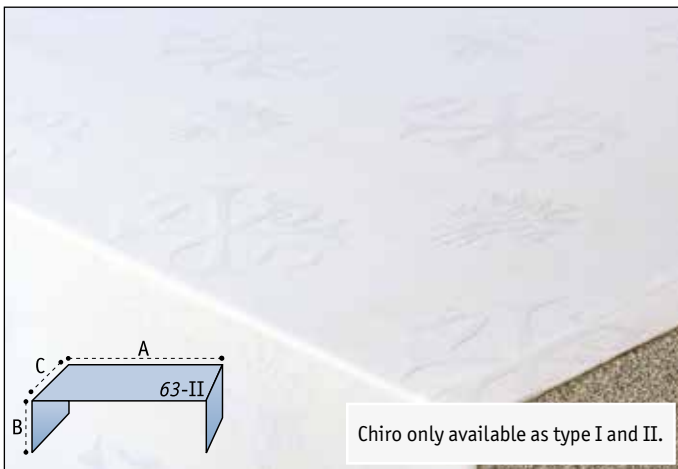

63-93 Chiro: white jacquard fabric of 100% Trevira, with woven chiro, wheat and grapes motifs (designed by Hendrik Slabbinck in 1923). Wash lukewarm.
 Total depth up to 51", price per yard \$ 90.00 finished.
 Total depth up to 76", price per yard \$ 132.00 finished; with seam.

Easy care altar cloth

These easy to maintain altar cloths for main and side altars are always custom-made; with a 1½" hem.

Fabric is added to the finished size for shrinkage at first laundering.

Prewash is possible if requested, **supplement is \$ 15.50.**

When ordering we require following information:

- ❶ type I, II, III or IV;
- ❷ dimensions; please indicate size of finished altar cloth according to "types" hereunder;
- ❸ fabric and price per yard of finished altar cloth.

For the price of your finished altar cloth, visit www.quotemyaltarcloth.com

❶ Types

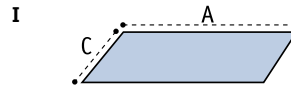

Covering altar mensa only.

Total length = A
 Total depth = C

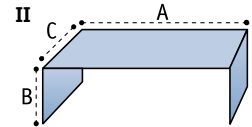

Covering altar mensa, with side drops.

Total length = A + 2 x B
 Total depth = C

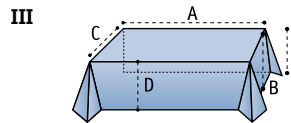

With square corners (tablecloth style), with front, side and back drops.

Total length = A + 2 x B
 Total depth = C + D + E

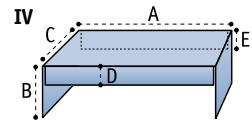

Covering altar mensa, with side drops and shorter front and/or back drop, with seam.

Total length = A + 2 x B
 Total depth = C + D or C + D + E

❷ Dimensions

- A = length of mensa
- B = side drops
- C = depth of mensa
- D = front side drop
- E = short back drop

❸ FABRIC AND PRICE PER YARD of finished altar cloth. Minimum charge one yard per cloth. All per yard prices include 1½" hem. Information: see above.

Type IV, **extra charge 10%.**



5368



5046



5047



5189



3500



2193



2194



2195



2196

Washable sacramental linens

- With motifs woven into the material.
- 3207** Eucharist motifs, 60% cotton and 40% linen; wash hot water.
- 3500** In **Alpha**, white fabric, 95% cotton and 5% linen. Wash hot water.
- With embroidered motifs on purificator, chalice pall and corporal; not on lavabo towel. Wash, lukewarm.
- 2193** Lamb of God, on Blended linen, of 55% linen and 45% man-made fibres.
- 2194** Eucharist (chalice, bread, grapes and wheat), on Blended linen, of 55% linen and 45% man-made fibres.
- 2195** Cross on "batiste" finest cotton and "ajour" hem stitched.
- 2196** Cross on Ravenna fabric of 70% man-made fibres and 30% viscose.
- 5046** In **Blended linen**, with fleur de lis cross.
- 5047** In **Blended linen**, with Canterbury cross.
- 5189** In **Blended linen**, of 55% linen and 45% man-made fibres, with gold-coloured cross and lines.
- 5368** In **Pure linen**, of 100% linen, white machine embroidered cross and motifs.

	Purificator 19½" x 11"	Lavabo Towel 19½" x 15¾"	Chalice Pall* 7" x 7"	Corporal 19½" x 19½"	Complete gift set
2193	\$ 57.50	\$ 40.00	\$ 83.00	\$ 73.00	\$ 253.50
2194	\$ 66.75	\$ 40.00	\$ 87.00	\$ 75.00	\$ 268.75
2195	\$ 37.75	\$ 45.50	\$ 63.00	\$ 76.00	\$ 222.25
2196	\$ 56.75	\$ 40.75	\$ 68.75	\$ 68.75	\$ 235.00
3500	\$ 40.00	\$ 43.50	\$ 49.00	\$ 49.00	\$ 181.50
5046	\$ 62.50	\$ 40.00	\$ 68.75	\$ 63.00	\$ 235.00
5047	\$ 68.75	\$ 40.00	\$ 78.00	\$ 69.50	\$ 256.25
5189	\$ 56.00	\$ 40.00	\$ 68.00	\$ 83.00	\$ 247.00
5368	\$ 114.00	\$ 73.00	\$ 75.00	\$ 215.00	\$ 477.00
	23½" x 15"	23½" x 15"	7" x 7"	23½" x 22½"	Complete set
3207	\$ 40.00	\$ 40.00	\$ 61.75	\$ 45.50	\$ 187.25

* Liner should be removed before laundering, if not, the pall should be washed in cold water.



3207



3722



2531

561

576



3722



3465



4375



3450

Multi functional travel bag. Light and easy to fold, with detachable shoulder strap. Long vestments, albs and personal clothing can easily be packed.

- Made in man-made fibres with an extra strong zipper. Size, when open: length 64½", width 23½", depth 2½". Large pocket outside and a smaller pocket inside.

3722 Clergy travel bag **\$ 136.00**

- Made in MM Microf polyester with an extra strong zipper. Size, when open: length 70", width 23½", depth 5". Size, when folded: length 23", width 23½", depth 10". Two large pockets outside and two on the inside.

3450 Clergy travel cover **\$ 295.00**

Travel cover. Easy transport, folds in half, with two handles. With name card holder.

- Made in man-made fibres, length 65", width 23½"; with extra strong zipper and large 10" by 12" front pocket.

3465 Clergy travel cover **\$ 55.50**

- Made in nonwoven fabric, length 63", width 26¾".

4375 Clergy travel cover **\$ 24.50**

Vestment hanger. Ideal to hang chasuble (with or without collar), dalmatic, cope, humeral veil, stole, lectern cover or superfrontal. With metal hook.

561 Solid wooden vestment hanger, 1" thick, width 23" **\$ 23.25**

F 576 Vestment hanger in wood-tone resin material; ½" thick, width 23" **\$ 18.95**

Cover. Protects vestments from dust and dirt.

Solid transparent vinyl, with zipper from top to bottom; all edges finished with ribbons.

2531 Cover; width 33", length 58¾" **\$ 24.50**

2654 As 2531, length 67¾" **\$ 26.00**



Original Stadelmaier® shirts

Enjoy the unique comfort of these refined European made shirts. Made of high quality wrinkle resistant and colour fast fabrics, of **65% polyester and 35% combed cotton**. Only available in black.

- **Tradicio:** European Tab Style, Clergy shirt with removable tab. Available with short, long and extra long sleeves. With two breast pockets. Convertible French cuffs for closure with either buttons or cuff links.
- **Torino:** Clergy shirt with a full attached Roman collar all around the neckline. Available with short, long and extra long sleeves. French cuffs for closure with cuff links only.

All shirts are available in sizes 15, 15½, 16, 16½, 17, 17½, 18, 18½, 19, 19½, 20 and 20½.
 Sizes for front shirt: 15, 16, 17, 18, 19 and 20.



#811

Tradicio
#811 Short sleeves \$ 86.00



#812

Tradicio
#812 Long sleeves (33-36) \$ 94.00
#813 Extra long sleeves (35-37) \$ 97.00



#862

Torino
#861 Short sleeves \$ 101.00
#862 Long sleeves \$ 104.00
#863 Extra long sleeves \$ 107.00



Original Slabbinck® shirts

Unique shirts, offering a wider cut and refined finish. Manufactured in a high quality **100% cotton**, for comfort and easy washing. Convertible French cuffs for closure with either buttons or cuff links. One breast pocket.

- **Classico:** Multiple colours available. An extra white tab is included with each shirt free of charge. Available with short and long sleeves.
- **Romano:** Clergy shirt with a full attached Roman collar all around the neckline. Only available in black. Long sleeves only.

All shirts are available in sizes 15, 15½, 16, 16½, 17, 17½, 18, 18½, 19, 19½ and 20; sizes 20½ only available in black.



#31



#35

Classico, short sleeves
#31 Black \$ 101.00
#35 Grey \$ 101.00



#17



#16

Classico, long sleeves
#16 Black \$ 101.00
#17 Grey \$ 101.00



#55



#55

Romano, long sleeves
#55 Black \$ 111.00



3846



3434



4813

Cuff links, info and prices on request.

General information: wash-and-wear fabrics for albs

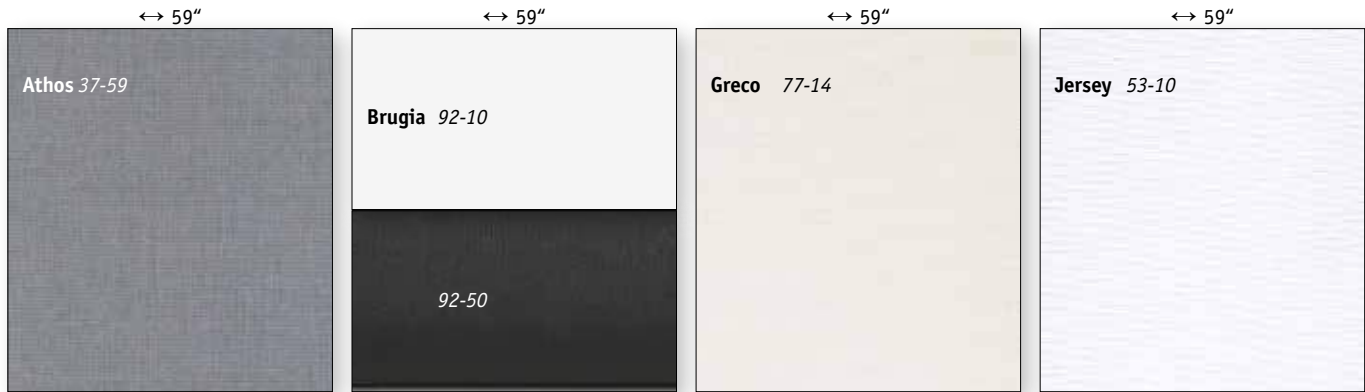

70% man-made fibres, 30% viscose, 200 g per m².
Price \$ 70.25/y.

100% wool, 180 g per m².
Price \$ 137.00/y.

70% man-made fibres, 30% viscose, 175 g per m².
Price \$ 59.50/y.

100% man-made fibres, 240 g per m².
Price \$ 61.75/y.



90% man-made fibres, 10% flax, 205 g per m².
Price \$ 59.00/y.

55% man-made fibres, 45% wool, 180 g per m².
Price \$ 114.00/y.

70% man-made fibres, 30% viscose, 265 g per m².
Price \$ 61.00/y.

100% man-made fibres, 150 g per m².
Price \$ 42.00/y.

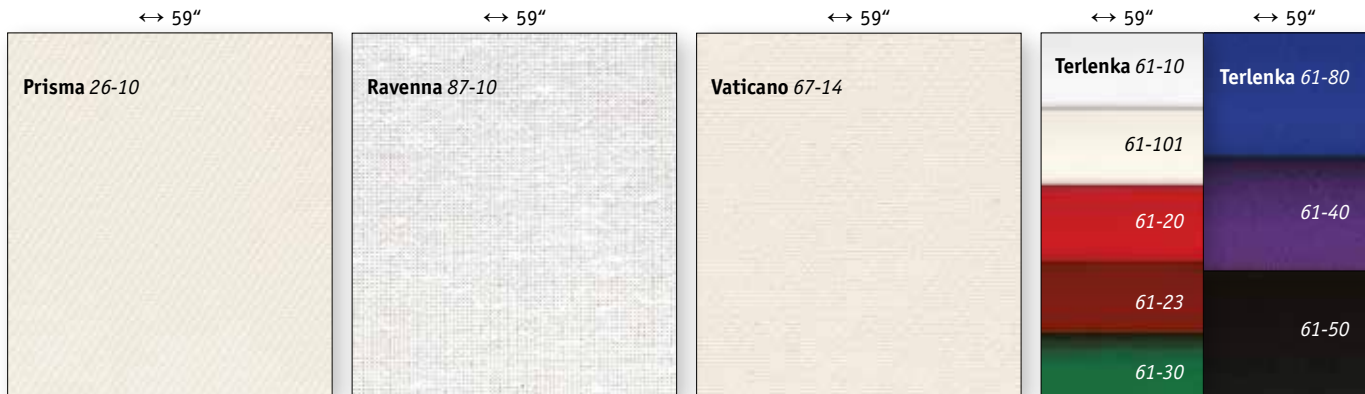

45% wool, 55% man-made fibres, 250 g per m².
Price \$ 94.00/y.

70% man-made fibres, 30% viscose, 210 g per m².
Price \$ 63.00/y.

70% man-made fibres, 30% viscose, 265 g per m².
Price \$ 59.00/y.

70% man-made fibres, 30% viscose, 175 g per m².
Price \$ 57.50/y.

Colour references in this catalogue are close to reality, but can't perfectly reflect it; if necessary please ask your sales representative for colour samples. Slabbincq nv declines any responsibility regarding colour discrepancies.

General information: fabrics for vestments and paraments



100% man-made fibres, white 230g per m²; other colours 145 g per m².
Price \$ 75.00/y.



100% wool, 180 g per m².
Price \$ 137.00/y.



61% wool, 33% man-made fibres, 6% lurex. 220 g per m².
Price \$ 143.00/y.

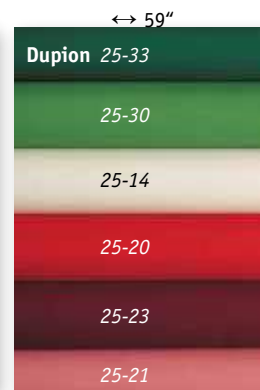

70% man-made fibres, 30% viscose, 200 g per m².
Price \$ 62.50/y.

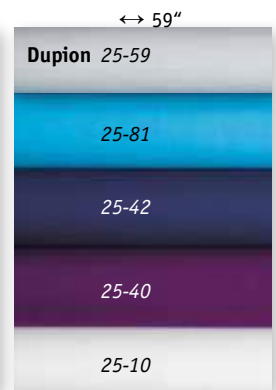

100% man-made fibres, 115 g per m².
Price \$ 101.00/y.



100% man-made fibres, 200 g per m².
Not available per yard.



53% man-made fibres, 31% cotton, 16% viscose, 325 g per m².
Price \$ 114.00/y.



99% viscose, 1% gold threads, 190 g per m².
Price \$ 108.00/y.

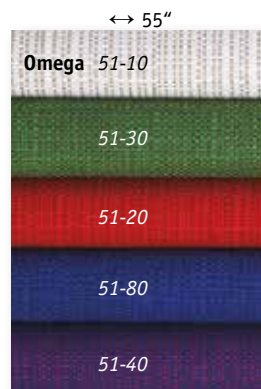

60% man-made fibres, 30% viscose, 10% flax, 325 g per m².
Price \$ 144.00/y.

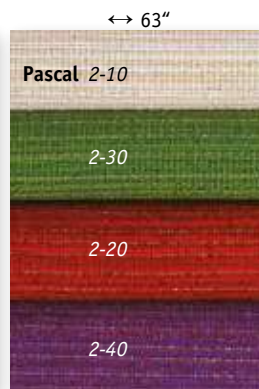

69% man-made fibres, 30% viscose, 1 % gold threads, 280 g per m².
Price \$ 116.00/y.

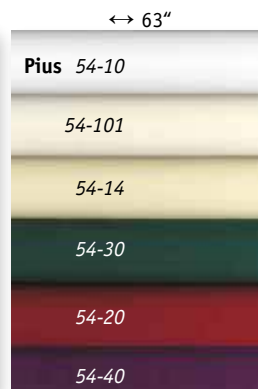

100% man-made fibres, 150 g per m².
Price \$ 42.00/y.

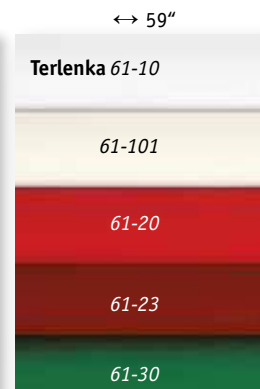

70% man-made fibres, 30% viscose, 175 g per m².
Price \$ 57.50/y.

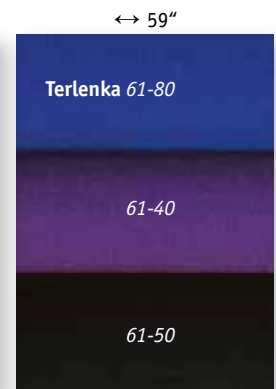

GENERAL INFORMATION: SIZES AND FINISHES

For standard and special sizes and neck finishes, as shown on illustrations, charts and sketches.
 All measurements are given in inches.
 We supply size and neckline, according to the illustration in the catalogue, unless otherwise specified in your order.
 Extra charges are possible for special designs and measurements.

Alb, Sanctuary Alb, Liturgical Gown, Tunic

Standard size

When ordering, only A-B = length to be indicated: from the top vertebra to the top of the shoe (12" less than person's total height).

Special size

I Standard size with minor adjustments

Adjustment A-B = back length and S-G = sleeve length; when ordering, please indicate desired standard size and quote special measurements A-B = back length, S-G = sleeve length and C = chest size.

Supplement for adjustment:

Back length and sleeve length **\$ 40.00**

II Entirely custom-made

Please give the following measurements: A-B = length, C = male chest size or female bust size, W = waist, S-S = shoulder to shoulder, S-G = sleeve length and A-G = measurement from centre back plus sleeve length; preferably also neck size or shirt number size.

Supplement **\$ 135.00**

When ordering, please specify if for a man or woman.

Surplice

Standard size

Chest 41".

Only A-B = length to be indicated when ordering:

- for altar servers: 16", 19½", 24" or 27";
- for adults: 35" (small), 38" (medium) or 41" (large).

Special size

I Standard size with adjustments

Indicate A-B = length, S-S = shoulder to shoulder and S-G = sleeve length when ordering.

Supplement **\$ 40.00**

II Entirely custom-made

Please give the following measurements: A-B = length, C = male chest size or female bust size, S-S = shoulder to shoulder, S-G = sleeve length.

Supplement **\$ 135.00**

Cope, Humeral veil, Mitre

• Cope

When ordering, indicate A-B = length of cope and person's total height (length of the cope is 14" less than person's height).

Without indication of length, we supply standard size 57".

Supplement lining for cope **\$ 590.00**

Overlay stole or inside stole NOT included in price of cope.

Please order separately.

• Humeral veil

Available with matching decoration.
 Standard finish is always lined.
 Size: 21" x 108".

• Mitre

When ordering, please indicate head size.

Chasuble, Monastic Chasuble, Dalmatic

Prices include (unless otherwise specified):

- small chasuble or dalmatic stole to be worn under the garment;
- if embroidered, same embroidery on front and back;
- neck finish according to catalogue;
- unlined.

Standard size

Style	A = width	B = length	Supplement
Small	59"-63" ¹⁾	49"	Basic price
Standard	59"-63" ¹⁾	53"	Basic price

¹⁾ According to the width of the fabric, see our website

Special size

2	Supplement monastic chasuble	\$ 102.00
9	Special, custom-made	upon request

Available at extra charge:

Chalice veil, unlined, 23" x 23"	upon request
Chalice veil, lined, 23" x 23"	upon request
Burse, 8" x 8"	upon request
Benediction burse (without embroidery), 9" x 9"	upon request
Chasuble or dalmatic inside stole to be worn under chasuble or dalmatic	upon request
Lining for chasuble or dalmatic	\$ 555.00

Dalmatic: a matching dalmatic is available for each chasuble.

Price upon request.

When ordering, please indicate style I, II, III, IV or V.

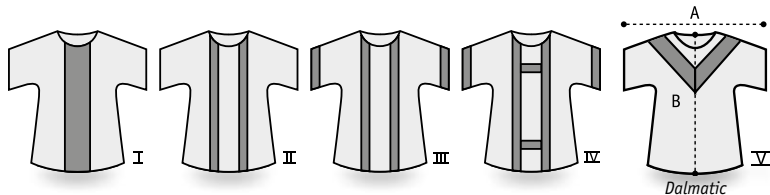

Neck finish

F = neck size; H = height of collar or capuche. The neck finish indicated in the catalogue is included in the price; other neck finishes are available at extra charge or reduction according to tariff below.

N°	Neck finish	F	H	Price difference
0	Plain	25"	-	Basic price
1	Plain neckline, with zipper on left shoulder	24¾"	-	\$ 31.50
3	Roll-collar	26"	4¾"	\$ 105.00
4	Roll-collar	25½"	3½"	\$ 157.00
6	Low stand-up collar	26¾"	3½"	\$ 96.00
6A	As 6, embroidered	26¾"	3½"	\$ 159.00

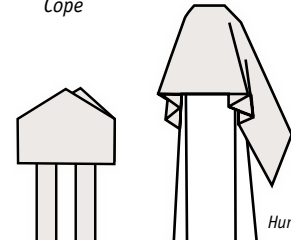
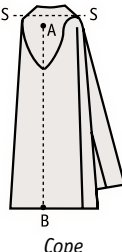
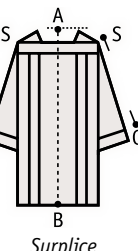
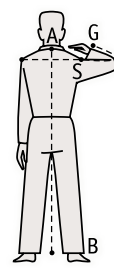
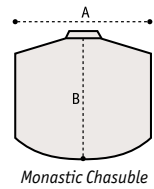
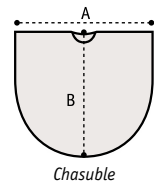
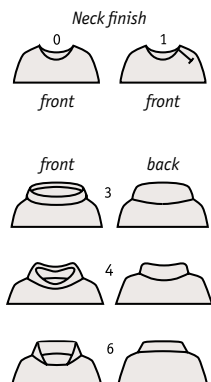
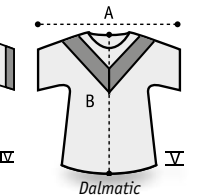

*In Loving Memory of
 Peter and Mary Jones*

GENERAL INFORMATION: SIZES AND FINISHES

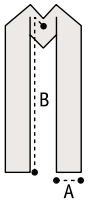

Overlay stole (single-sided or reversible), Deacon stole

• **Overlay stole**
Always lined and interlined; available with different neck finishes, supported by an elegant chain (except style 107), which prevents the stole from rubbing neck or hair, and saves the use of a stole protector.

I Single-sided overlay stole

Style and neck finishes: A = width at ends; B = overall length, neck finishes included. The neck finish indicated in the catalogue is included in the price; other neck finishes are available at extra charge or reduction, upon request.

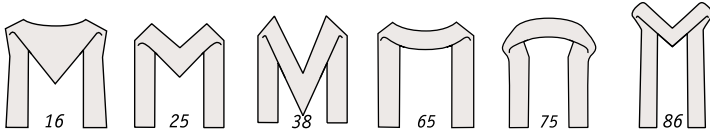

N°	Neck finish	Width A	Length B
16	Full tapered flat capuche; spreading out towards ends	6 7/16"	63"
25	Flat capuche	4 3/4"	57"
38	Tapered flat capuche	4 3/4"	61"
65	Flat rounded neck finish	4 3/4"	57"
75	Stand-up collar	4 3/4"	57"
86	Pointed flat capuche; spreading out towards ends	6 7/16"	63"
107	Flat rounded neck finish with cutouts in front	5 1/8"	57"

II Reversible overlay stole

Manufactured like the overlay stole, but reversible: white-purple, red-green or other colour combinations.

• **Deacon stole**

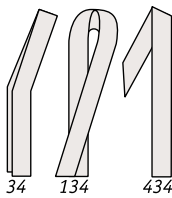

Matching the design of the overlay stole. Worn from left shoulder to right hip. Deacon stoles will be delivered for a standard chest size 37"-45". On request deacon stoles can be made to custom size at no additional charge. Standard chest size (37"-45") will be supplied unless otherwise requested. Style 34: embroidery in front at chest height, on back on lower panel (price see style 25).

Style 134: Crossed style

Style 434: Byzantine cut, with band front and back.

N°	Type	Width A	Length B
34	Standard	4 3/4"	57"
34	Standard larger size upon request	4 3/4"	61"
134	Crossed style	4 3/4"	57"
434	Byzantine	4 3/4"	51"

Lectern cover, Pulpit cover, Altar paraments, Altar cover, Antependium, Half Altar cover

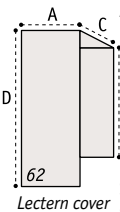

Lined and interlined; finished with an open hem at the top and the bottom; microphone opening to order²⁾.

• **Lectern cover, style 62**

A = width up to 24" (at indicated price, without supplement); D = front drop; C = depth; E = back drop; D + C + E = overall length.

Standard sizes D + C + E = 71". A = 18". D = 43".

Special sizes If longer or deeper than standard sizes, add a supplement per inch upon request.

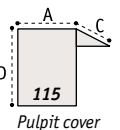

• **Pulpit cover, art. 115**

Same finish as lectern cover art. 62, but with different standard sizes and special sizes.

Standard sizes D + C = 39 3/8". A = 17 3/4". D = 21 1/2".

Special sizes If longer or deeper than standard sizes, add a supplement per inch (same as for lectern cover art. 62) upon request.

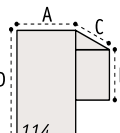

• **Altar paraments, style 114**

Same finish as lectern cover art. 62, but with different standard sizes and special sizes.

Standard sizes D + C + E = 59". A = 17 3/4". D = 29 1/2".

Special sizes If longer or deeper than standard sizes, add a supplement per inch (same as for lectern cover art. 62) upon request.

• **Altar cover, style 64**

A = width up to 41 1/8" (at indicated price, without supplement); D = front drop; C = depth; E = back drop; D + C + E = overall length.

Standard sizes D + C + E = 75". A = 36". D = 36".

Special sizes If longer or deeper than standard sizes, add a supplement per inch upon request.

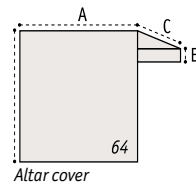

• **Antependium, style 112**

A = width up to 71" (at indicated price, without supplement); D = front drop; C = depth; E = back drop; D + C + E = overall length.

Standard sizes D + C + E = up to 75". A = up to 71". D = 36".

• **Half altar cover, style 113**

Same as antependium, style 112 but with different standard sizes and special sizes.

Standard sizes D + C + E = up to 51". A = up to 71". D = 14".

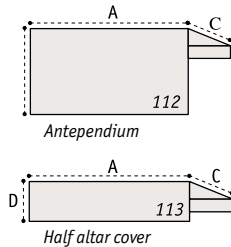

Altar cloth, Laudian frontal, Half Laudian frontal

Microphone opening and special cut-out (e.g. tabernacle) to order²⁾.

• **Altar cloth, style 63**

When ordering, indicate measurements for finished altar cloth; A = length of mensa; B = side drops; C = depth of mensa; D = front drop; E = back drop.

If depth (C) is over the width of the fabric, the altar cloth is finished with a seam.

There is 1 yard minimum charge.

The necessary fabric is added to the altar cloth (style 63), to compensate for shrinking during first laundering. Due to the different washing and laundering procedures, the fabric may shrink more or less than anticipated. Therefore, all altar cloths are provided with a large hem of 1 1/2" to be adjusted if necessary.

Prewash is possible if requested, supplement is \$ 15.50

The front and back drop of type IV, are always attached by seams to the altar cloth.

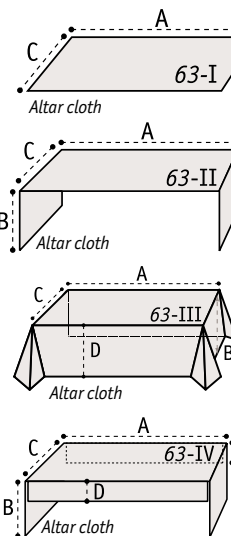

• **Laudian frontal, style 66**

Covers the altar on all sides, corners are rounded. Interlined. Finished with a middle seam in the length. When ordering, indicate measurements for finished laudian frontal:

A = length of mensa; C = depth; D and E = equal front and back drops, usually 2" less than altar height.

Special sizes

If the measurement A is more than 71", supplement per inch

price upon request

If the measurement C + D + E is more than twice the width of the fabric minus seam and hem

price upon request

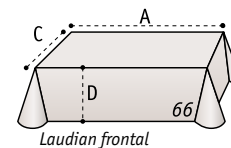

• **Half Laudian frontal, style 166**

Same as laudian frontal, style 66, but with shorter front, back and side drops D and E up to 10".

Special sizes

price upon request

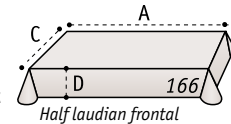

Interchangeable altar panels

• **Interchangeable superfrontal, style 69**

Adorns front of altar cloth. When ordering, please indicate: A = length of mensa (standard length 71"; over 71", supplement per inch);

D = height (standard ht. 10"; over 12"; supplement per inch)

prices upon request

²⁾ Microphone opening, supplement of

\$ 24.50

Special cut-out, supplement of

\$ 40.00

No deduction for less than standard size.

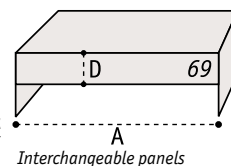

info@slabbinck.com

www.slabbinck.com



SLABBINCK®

IN SERVICE OF LITURGY SINCE 1903
IN BRUGES, BELGIUM